

Eirik Comes To Ireland

1. Introduction, *page 2*
2. Preparation for the Visit, *page 3*
3. The Visit, *page 4*
 - Vikings in Scandinavia and their travels
 - Vikings in Ireland
 - Jewellery Workshop
4. Follow-up Activities, *page 5*
5. Curriculum Links, *page 6*
6. Background Information
 - a) Vikings in Scandinavia, *page 7*
 - b) Vikings in Ireland, *page 8*
 - c) Vikings in Fermanagh, *page 9*
 - d) Vikings in Dublin, *page 10*
 - e) Viking Ships, *page 11*
 - f) Viking Ship Building, *page 12*
 - g) Viking Jewellery, *page 13*

***Teacher's Information Pack produced by:
Fermanagh County Museum, Enniskillen Castle,
Tel: +44 (0) 28 6632 5000.
Email: castle@fermanagh.gov
A Fermanagh District Council Facility***

1. Introduction

Thank you for booking *Eirik Comes to Ireland* Viking programme at Fermanagh County Museum.

Please read through this booklet as it contains important information regarding activities during the visit, as well as activities to do before and after your visit.

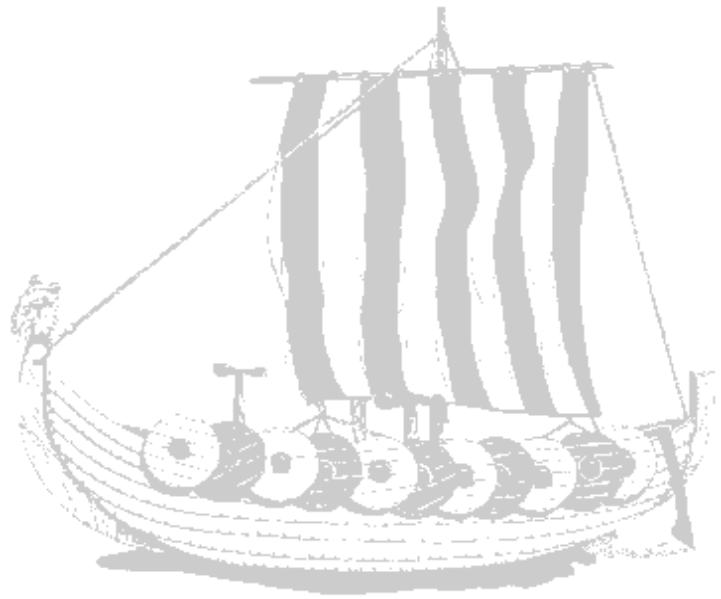
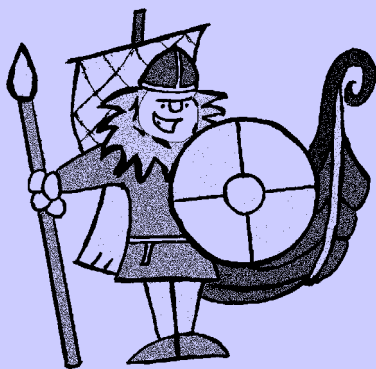

Is *Eirik Comes to Ireland* linked to the curriculum?

This module is linked closely to the national curriculum. It has been carefully structured to take children through a series of activities that will enhance their understanding of Vikings and their influence around the world.

For curriculum links see page 6.

Aims of Eirik Comes to Ireland

To achieve understanding and appreciation of the Vikings.

Children taking part in the module will:

- realise that Viking people were not all warriors;
- explore Viking ship building techniques and appreciate how advanced their technology was for the time;
- investigate Viking artefacts and piece together a picture of Vikings in Ireland.

2. Preparation for the Visit

The following notes are designed to enhance children's appreciation of their visit and should take no longer than one hour to implement.

Getting the most from your visit

Local newspapers are often willing to send along a photographer to record the day and to publish the school, an accompanying letter from the children to the paper is usually quite effective.

Explain to the children that they are invited to journey back in time to imagine what it would be like to be a Viking.

Mention a little bit of what they will be doing to whet their appetite!

Explain that the time period of the Vikings in Ireland was during the 9th - 11th century, and that it was mainly Norwegians and Danes that come to Ireland. This module focuses mainly on the Norwegian settlement in Ireland during the 10th century.

Ask children to think about what it would be like to become a Viking? Would it be scary or exciting? What do they think it would have been like to travel on long voyages? What things do they think the Vikings would have taken with them on their travels? What would it be like to settle in a foreign country? Are they looking forward to their visit?

It is helpful if the children know the definitions of these **key terms** prior to their visit:

<i>Artefacts</i>	Objects used by people a long time ago
<i>Evidence</i>	Clues which help to solve a puzzle
<i>Archaeology</i>	The study of artefacts to learn about the past
<i>Excavate</i>	To dig in search of artefacts
<i>Thing</i>	A Viking meeting/council
<i>Annals</i>	Records kept by Irish monks
<i>Thralls</i>	Vikings who owned no land
<i>Karls</i>	The average Viking land owner/farmer
<i>Jarl</i>	Powerful, wealthy land owners

To conclude please write the children's names on the adhesive labels enclosed as this helps the education staff to give a more personal touch to your visit.



3. The Visit

Throughout your visit the children will be guided around the exhibits by staff, but your involvement will be most appreciated.

Your visit will consist of a series of activities each linked to the next. We have tried to make the activities as exciting and participative as possible.

Before your arrival at the castle:

1. Please have the children separated into _____ groups;
2. Before leaving the bus please encourage children to take off their coats and have their name badges in place.

Please bring with you:

- A box for the brooches
- A camera (If you wish)

Activity One - Vikings in Scandinavia



This activity deals predominantly with the lifestyle of Viking people in Scandinavia. The children are seated as if they are within a Viking longhouse and the following are discussed:

- Longhouse construction
- Social structure (jarl, karl, thrall)
- Food and cooking
- Clothing and accessories (eg belt, jewellery, pouch, sewing kit etc)
- Weaponry (examples of helmet, sword and shield can be handled by children)

The next activity entails a role play situation whereby the children interact within a Viking meeting (*Thing*). The main issue of discussion is the 'intended' Viking voyage to Ireland and after they are given the appropriate information the children are asked to discuss and plan this trip. In doing so topics such as ship types, construction and navigation are considered. The Viking 'recruits' then have the opportunity to perform a 'Viking Raid' on Ireland.

Activity Two - Vikings in Ireland

This session is given a different slant with the emphasis being upon the appreciation of Viking artefacts found in Ireland. Here they become assistants to an archaeologist and undertake an excavation of artefacts. Using the artefacts excavation boxes they will explore:

- Evidence of Vikings in Ireland
- Vikings in Armagh, Fermanagh and Dublin
- Trade and jewellery
- The impact Vikings had upon Irish society

Activity Three - Jewellery Workshop

Children design and make a Viking brooch after a short talk on the principles of Viking jewellery design.

4. Follow-Up Activities

In order to get the maximum benefit from your visit, please conduct post-visit work with your class.

The following suggested activities are designed to reinforce the various aspects of your group's visit to the exhibition.

Follow-up for "Vikings in Scandinavia"

A worksheet is provided within this pack if you wish to photocopy it for your class. It covers some of the main themes of the education programme, and encourages children to finish the Viking Detective Workbook.

Follow-up for "Vikings in Ireland"

Continuing with the theme of archaeology, bury some objects inside a large container of sand and get the children to 'excavate' the 'artefacts' by gently removing the sand layer by layer. Some suggestions for artefacts could be:

- pieces of leather
- pieces of wood
- metallic objects such as foil
- glass beads

Encourage the children to write or draw a description of the object; record and identify the object's material; and estimate the depth it was found. Once this is completed explain to the children that because the objects are not well preserved there is only a small portion still remaining. Therefore it is necessary to decide what the object could have been before it deteriorated, what it might have been used for, and where it might have been sourced from eg the metal might have been part of a Viking brooch/pendant/bracelet, worn by wealthier members of Viking society perhaps originally stolen during a raid in Ireland.

Follow-up for the Jewellery Workshop

Repeat a similar workshop to the one children experienced at the Museum using a circular piece of card and gluing on various pasta pieces. Plastic lids from circular containers (eg Pringles, coleslaw pots) could be used as an alternative to cardboard. As they now have a pair of brooches a necklace could be made to join them by threading beads or hollow pasta onto wool or thread. Once it is dry gold or silver spray paint could be used to give it a metallic feel. A safety pin or double-sided sticky tape affixed to the back of the brooches would enable them to be attached to their clothing.

5. Curriculum Links

National Curriculum History

From Key Stage 2 Programme of Study

Historical Skills & Concepts

Pupils should have the opportunity to develop:

- a sense of the past by identifying some things that have changed and some things which have remained the same.

Example from programme: Comparison of Viking tool design with that of today.

- some of the feelings people may have had at a time in the past.

Example from programme: Pupils are given opportunities to consider Viking views by becoming actual Vikings.

- awareness of evidence, historical enquiry and interpretation by: using sources of information to gain information about an aspect of the past

Example from programme: Visiting a museum and interpreting artefacts satisfies this requirement.

The Vikings

Pupils should be given opportunities to investigate:

- Viking way of life at home;
- Viking expansion and settlement abroad;

Example from programme: The programme deals with the homelife of the Vikings, exploration and settlement abroad, as well as the Viking impact on Early Christian Ireland

- a local dimension linked to the Vikings.

Example from programme: Children are able to investigate evidence of Viking activity in Fermanagh.

National Curriculum English

From Key Stage 2 Programme of Study

Pupils should be given the opportunities to talk for a range of purposes including:

- exploring, developing and explaining ideas
- planning, predicting and investigating
- sharing ideas, insights and opinions

Example from programme: During the 'Thing' exercise children are given the

opportunity to develop their own ideas through group discussion.

National Curriculum Design & Technology

From Key Stage 2 Programme of Study

Pupils should

- be given opportunities to develop their capability through assignments in which they design and make products.
- generate ideas considering the purpose for which they are designing
- combine materials in temporary ways.

Example from programme: Designing and constructing the Viking brooch.

National Curriculum Science

From Key Stage 2 Programme of Study

Pupils should be taught: to make careful observations and measurements

Example from programme: Observation and recording of artefacts within the exhibits.

6a. Background Information

Spring was very busy for the Viking farmer - ploughing and sowing seeds. As soon as the majority of the work was completed it was commonplace for the farmer to leave responsibility for the farm to his wife while he spent the summer raiding and trading. He would return in Autumn to harvest his crops, and preserve meats and vegetables for the long winter ahead. As the winter tended to be dark all of the time it was spent repairing tools, and boats, as well as making shoes, harnesses and sleeping bags.

Vikings in Scandinavia

Viking Houses

The Viking longhouse was extremely versatile as a single room could be used for all the requirements of the daily routine such as eating and sleeping etc. The benches which spanned the length of the dwelling enabled this versatility as they could be used for seating as well as beds. In the centre of the house was a long hearth which was known as the fire-hall or *scali*. There was a hole in the centre of the roof to allow the smoke to escape, but it is assumed that it would be continually smoky within. Due to its wattle and daub construction the roof would sag after about 15 years and it was necessary to build another dwelling.



Social Structure

Social rank within Viking society was based upon land ownership and wealth, and it was possible to distinguish different classes by their clothing and jewellery. There were three main tiers:

- Jarls** - powerful/rich land owners. It was common for one of the Jarls in the district to be a leader or even a king. Jarls were responsible for leading a meeting (Thing).
- Karls** - tended to be the largest group owning a modest size of land.
- Thralls** - slaves, prisoners who owned nothing, and had no rights. Although if they worked hard they were given the opportunity to buy their freedom and in doing so climb the social ladder.

6b. Background Information

Vikings created the foundation of coastal towns in Ireland: Dublin, Limerick, Waterford and Cork during the 9th Century.

During the Viking age (800-1100AD), many Irish people lived in raths. A rath was made by digging a circular ditch and using the soil to build a surrounding bank. Inside the rath were farm buildings and a house.

Vikings in Ireland

Until comparatively recently knowledge on Viking activity in Ireland was mainly based upon documentary sources, such as the annals, and some linguistic and place-name evidence.

Recent excavations within the walls of medieval Dublin have uncovered well preserved archaeological deposits, and consequently identified Viking Dublin as a very important trading town.

Unfortunately, elsewhere in Ireland there tends to be a lack of archaeological evidence and knowledge is mainly based on the annals and other documentary sources.

The first recorded Viking raid took place on Rathlin Island, Co Antrim, in 795AD. These Vikings had journeyed from the Shetlands and Orkneys which were close by. By 820AD raids were becoming more frequent and widespread and by 830AD raids started moving inland.

In 838AD the raiders sailed up the Shannon river and penetrated Lough Erne. In 839AD Lough Neagh was the location for the first recorded overwintering, and within two years the first permanent settlements within naval camps or *longphort*, were established in Dublin and Annagassan, Co Louth.

The Viking age in Ireland continued until the 11th century.

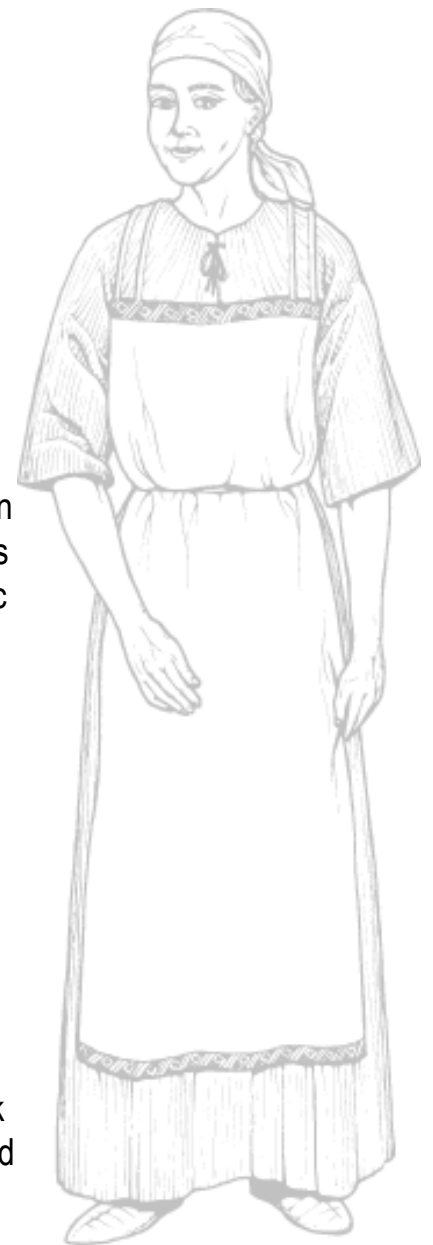

6c. Background Information

Few Viking related artefacts have been found in the Fermanagh area, therefore evidence of the influence of the Vikings is mainly dependant upon documentary sources:

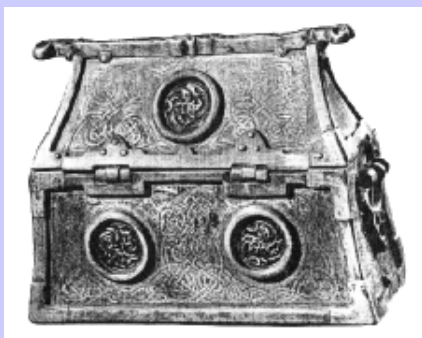

Shrine found in Lough Erne

Vikings in Fermanagh

In the **Annals of Ulster 837AD:**

“All the churches of Loch Erne together with Cluain Eois (Clones) and Daimhinis (Devenish) were destroyed by Gentiles (Vikings).”

North men from Scandinavia and Denmark attacked again in **924AD:**

“a fleet of Foreigners on Lough Erne plundered the islands of the lake and the territories around it to and fro and departed the following summer”.

One monk noted:

***“Bitter is the wind tonight;
It tosses the ocean’s white hair;
Tonight I fear not the fierce warriors of Norway;
Coursing the Irish sea.”***

The **Annals of the Four Masters** in the year **931AD** wrote: ***“The foreigners took up their station upon the lakes of Erne; and they spoiled and plundered many districts and churches, as far as Loch Gamhna (Lough Gowna, Co Longford)”.***

Unfortunately no evidence of a permanent fortress (longphort) has been found nearby, however they certainly had a base near Caol Uisce, near Belleek and from there made raids up the lake.

Monasteries would have been vulnerable to Viking attacks, such as White Island, Boho, Inishmacsaint Island, and Kilcoo. The thriving monastery on Devenish Island in Lower Lough Erne was also an attractive target for the Vikings in their search for food, wine and religious treasures.

Lough Erne fishermen in 1891 discovered an 8th century shrine and this **may** have been stolen during a Viking raid of a religious foundation. Ornaments made from fragments of Irish shins were highly fashionable among Norse ladies and have been frequently found in Viking graves.

6d. Background Information



At first Viking camps in Ireland began as fortified structures called longphorts. As time went by and various settlements became more important in terms of trade, these camps eventually became thriving towns. Dublin became the main Irish port for importing and exporting goods. Ireland did not have of towns prior to the Vikings.

Vikings in Dublin

Woodquay, Dublin is the location for the largest Viking archaeological excavation outside of Scandinavia. This has enabled an extensive knowledge of Viking lifestyle to develop which shows how Viking culture affected the Irish way of life.

The streets in Viking Dublin were very narrow; little more than two metres wide and were covered with gravel and stones or paved with split logs. The houses were rectangular in shape, arranged in rows, and fronted by a small plot of land where the household rubbish and sewage were thrown. Occasionally pigs would also be kept in this area. The construction of the houses are very similar to that of Scandinavia, except that the roof is thatched as opposed to being covered with daub (mud). Generally there would be a door at either end of the dwelling. At the back of the house there often would be a small store house built and thatched like the main building but without the daub on the walls.

Trading

Archaeologists have excavated a multitude of objects which have been sourced from distant countries, demonstrating how extensively trade developed:

- Wine jugs from France and Italy;
- Pottery from England;
- Bowls from the Shetland Islands;
- Silk from Turkey;
- Swords from Germany, and;
- Marble tiles from Italy.

Exports from Ireland included metal work; jewellery; slaves; food for trading ships on long voyages.

Coinage

The first coins in Ireland were minted in Dublin in 997. Prior to this, the Irish traded commodities such as cattle, and the Viking settlers used hack silver and coins from other countries.

6e. Background Information

Whats in a name?

The Vikings have a bad reputation as savage warriors and bloodthirsty pirates and this is reflected in their name.

It was not until the 1100's that the word Viking was used to describe Norsemen. In old Norse the word Vik means a bay/fjord, referring to the bays where they hid to ambush passing ships. The term Viking means a pirate/robber and to go 'Viking' means to go raiding overseas.

Viking Ships and Ship Building

Types of Viking Ships

All Viking ships were similar in design - they were long and slender with a high curve at each end.

A. Long ships - They were light enough to sail in shallow water and strong enough to survive a storm as they were flexible and bent with the waves. These ships were used for raids and warfare. The prow of a longship was often carved with a dragon's head and brightly painted. Vikings gave their ships names such as Long Serpent, Bison, Strider, and Crane. Longships could be carried by their crew across land turned upside down.

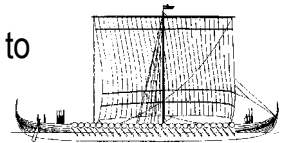

B. Cargo ships used for trade were known as "Knarr" which were different to long ships. Built of oak or pine, high and wide and two half decks at the fore and aft to allow for a hold in the middle where the cargo was stored.

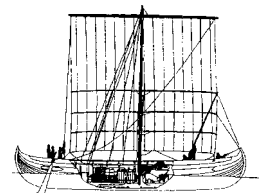

C. A "Faering" was a four oared boat for four men and could be carried upon a long ship when not in use. Vikings often travelled great distances inland and landed at places where there were no harbours.



Life Under Sail

Life on board ship was difficult and dangerous, and Vikings wrote long epic poems or sagas about their voyages. The sailors carried their personal possessions in trunks, and they sat on these when they were rowing. The rowing on longships was shared between two teams who took it in turn to row. Fresh water was carried in barrels along with vats of butter, cheese, barrels of beer and sour milk, sacks of apples, nuts, meat and fish dried, smoked or salted. Awnings and tent poles were carried to make shelter on landing and also cauldrons for preparing meals on land. Meals were prepared on ship by containing a fire within a light box.

6f. Background Information

The Vikings used a bearing dial to work out their location in relation to the position of sun at midday. An example of a bearing dial with 32 points was found in Greenland in 1948.

Landmarks were used while navigating along the coastline. Guides could be hired to assist with this.

When they were on the open sea they depended upon the sun, stars and bird life.

Viking Ship Building

How Vikings built their ships

Viking ships were clinker built. This means that after the first line of planks had been fixed in place with iron nails, the 2nd line was fastened above them. The wedge shape allowed this second line to overlap the first. As a result the ship is structurally flexible and consequently quite robust on the open sea. Within the overlapped sections of the planks was a groove in which a caulking material could be placed, such as wool and oil ensuring that the vessel would be watertight. When the vessel entered the sea for its first sailing the timber would swell allowing a very tight seal to be achieved.

Oarholes were cut into the top plank at each end of a merchant cargo ship and along the full length of a longship. The keel was the backbone of the ship. Two end posts were added onto each end to give the ship its distinctive curved shape. Planks/strakes were fastened unto the keel starting at the bottom. The mast block was fixed to the keel in the middle of the ship. The slot in the middle for the mast distributed the weight evenly.

Their combination of sail and rowing, tapering of the planks at the bow and stern, and their rudder design made them the most effective naval power in Europe of the time, as well as the most technologically advanced.

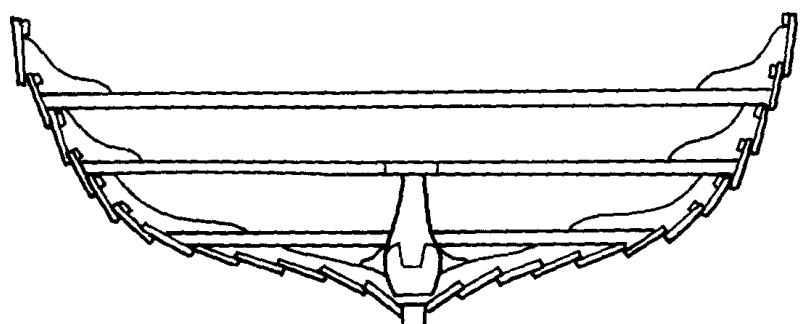
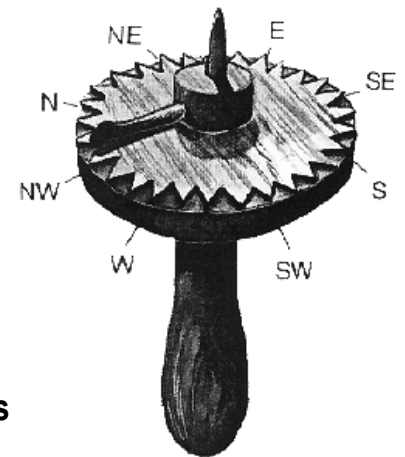

6g. Background Information

Jewellery was not only used for purely decorative purposes, it was also functional:

men used a ring pin to attach their cloak to their tunic;

women used two “tortoise” brooches joined with beads to attach their aprons to their dresses or shifts.

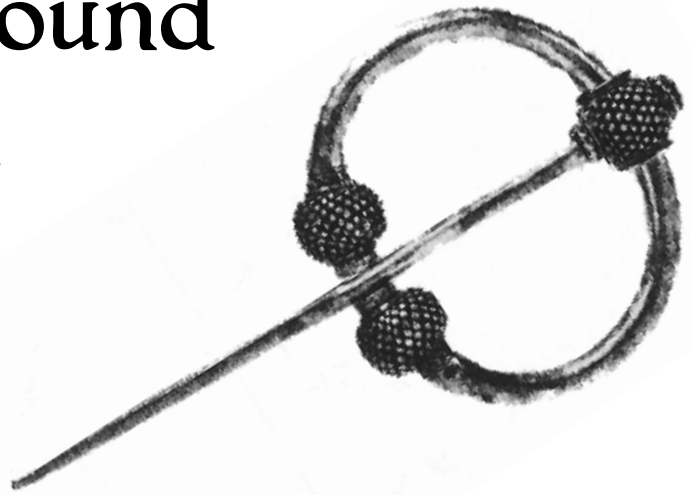

Viking Jewellery

The Vikings loved fine decorative jewellery. Everyone in Viking society except slaves appears to have worn jewellery, the finest pieces however would only have been worn by wealthy individuals with high social status.

The Vikings were skilled craftsmen who practised their intricate symmetrical designs first on animal bone before transferring them to precious and semi precious metals. Some examples of worked animal bones were found at the Wood Quay excavation, Dublin. They also used amber which was washed up on the Danish coast and jet traded from mines in Yorkshire, England.

Many pieces were made from silver which appears to be the Viking's favourite precious metal, even above gold. A common source of silver used for jewellery came from shrines and other religious articles brought back from raids on church communities.



Vikings Worksheet

Ethel the Viking hopes that you enjoyed your day at Enniskillen Castle. This worksheet will help you to remember your visit:

1. Write the name of the Viking boat below its picture:

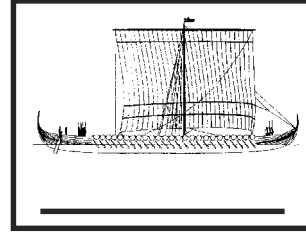
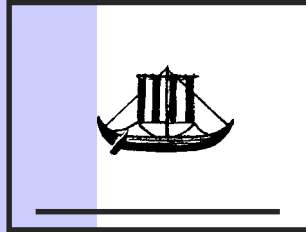
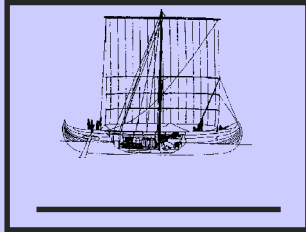

Clue
Choose from
Long boat
Cargo (knorr)
Faering

2. Vikings used the sky to work out where they were. They navigated by using the _____ during the day and _____ during the night.

3. What was the name of a Viking meeting? _____

4. Why did Ethel (Eirik's wife) wear a scarf on her head? _____

Write your name using the Viking rune alphabet

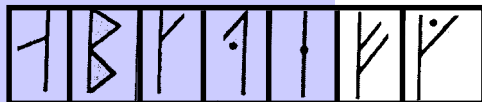

A B C D E F G



H I J K L M N O



P Q R S T U V W X

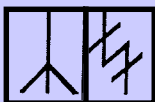

Y Z

Complete this picture of a Viking woman. Draw:

- * a belt, * a key,
- * a pouch for holding sewing kit,
- * a pouch for holding shears,
- * two brooches joined with string of beads

